



Air Conditioning & Heating



COOLING CAPACITY
18,000 TO 56,800 BTU/H

PRODUCT SPECIFICATIONS



SSX14

14 SEER / R-410A

HIGH-EFFICIENCY

1½- TO 5-TON

SPLIT SYSTEM AIR CONDITIONER



The Goodman® SSX14 Air Conditioner uses the environmentally friendly refrigerant R-410A, which is chlorine-free to help prevent damage to the ozone layer. This unit features a high-efficiency Copeland® scroll compressor plus energy efficiencies and operating sound levels that are among the best in the heating and cooling industry. The SSX14 is designed for the consumer who desires superior comfort, quiet operation, and environmentally friendly performance.

Standard Features

- R-410A environmentally friendly refrigerant
- High-efficiency Copeland® scroll compressor
- High- and low-pressure switches
- High-quality compressor sound blanket
- 850-RPM condenser fan motor
- Liquid refrigerant return protection
- Factory-installed, bi-flow liquid line filter dryer
- Service valves with sweat connections and gauge ports
- Copper tube/enhanced aluminum fin coil
- Reliable time-initiated, temperature-terminated defrost control
- Service valves with sweat connections and easy-access gauge ports
- Contactor with lug connection
- Ground lug connection
- ARI Certified; ETL Listed

Cabinet Features

- Unique Goodman® sound control top design
- Steel louver coil guard
- Heavy-gauge galvanized-steel cabinet
- Attractive Architectural Gray powder-paint finish with 500-hour salt-spray approval
- Top and side maintenance access
- Single-panel access to controls with space provided for field-installed accessories
- When properly anchored, meets the 2001 Florida Building Code unit integrity requirements for hurricane-type winds

Accessories

- See list of accessories on Page 2.



PRODUCT SPECIFICATIONS

NOMENCLATURE

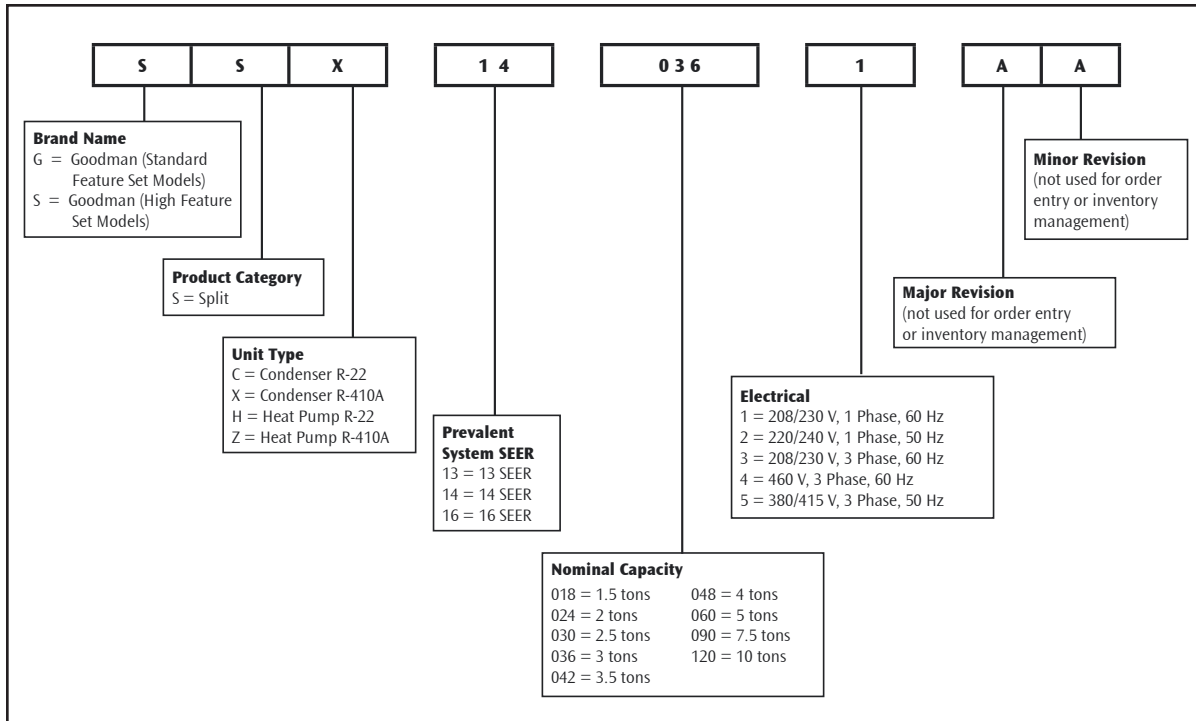

ACCESSORIES

Model	Description	SSX14 018	SSX14 024	SSX14 030	SSX14 036	SSX14 042	SSX14 048	SSX14 060
ABK-20	Anchor Bracket Kit *	X	X	X	X	X	X	X
ASC-01	Anti-Short Cycle Kit	X	X	X	X	X	X	X
CSR-U-1	Hard-start Kit	X	X	X	X			
CSR-U-2	Hard-start Kit				X	X	X	X
CSR-U-3	Hard-start Kit						X	X
FSK01A ¹	Freeze Protection Kit	X	X	X	X	X	X	X
LSK01A	Liquid Line Solenoid Kit	X	X	X	X	X	X	X
OT18-60A	Outdoor Thermostat / Lockout Stat	X	X	X	X	X	X	X
TX2N4 ²	TXV Kit	X						
TX3N4 ²	TXV Kit		X	X	X			
TX5N4 ²	TXV Kit					X	X	X

* Contains 20 brackets; four brackets needed to anchor unit to pad

¹ Installed on indoor coil

² Field-installed, non-bleed, expansion valve kit — Condensing units and heat pumps with reciprocating compressors require start-assist components when used in conjunction with an indoor coil using a non-bleed thermal expansion valve refrigerant metering device.

SPECIFICATIONS

	SSX14 0181A	SSX14 0241A	SSX14 0301A	SSX14 0361A	SSX14 0421A	SSX14 0421B	SSX14 0481A	SSX14 0601A
Cooling Capacity								
Nominal Cooling (BTU/h)	18,000	24,000	28,800	34,600	40,000	40,000	45,000	56,800
Decibels	70	71	72	73	73	73	74	75
Compressor								
RLA	9.0	13.4	12.8	14.1	17.9	17.9	19.8	26.4
LRA	48.0	58.3	64	77	112	112.0	109	134
Condenser Fan Motor								
Horsepower (RPM)	1/12	1/12	1/6	¼	¼	1/6	¼	¼
FLA	0.60	0.60	1.50	1.60	1.60	1.00	1.60	1.60
Refrigeration System								
Liquid Valve Size ("O.D.")*	⅜"	⅜"	⅜"	⅜"	⅜"	⅜"	⅜"	⅜"
Suction Valve Size ("O.D.")*	¾"	¾"	¾"	⅞"	⅞"	⅞"	⅞"	⅞"
Valve Connection Type	Sweat	Sweat	Sweat	Sweat	Sweat	Sweat	Sweat	Sweat
Refrigerant Charge	130	135	140	155	180	170	195	280
Shipped with Orifice Size	0.049	0.057	0.063	0.067	0.074	0.074	0.079	0.088
Electrical Data								
Voltage-Hz / Phase	208/230-60-1				208/230-60-1			
Minimum Circuit Ampacity ¹	11.8	17.4	17.5	19.2	24.0	23.4	26.4	34.6
Max. Overcurrent Protection ²	20	30	30	30	40	40	40	60
Min / Max Volts	197 / 253				197 / 253			
Electrical Conduit Size	½" or ¾"				½" or ¾"			
Ship Weight (lbs)	178	178	195	199	207	207	242	280

* Up to 35' in equivalent line length

¹ Wire size should be determined in accordance with National Electrical Codes; extensive wire runs will require larger wire sizes

² May use fuses or HACR type Circuit Breakers of the same size as noted

Important EnergyStar Notice: Proper sizing and installation of equipment is critical to achieve optimal performance. Split system air conditioners and heat pumps must be matched with appropriate coil components to meet EnergyStar criteria. Ask your contractor for details or visit www.energystar.gov.

PRODUCT SPECIFICATIONS

DIMENSIONS

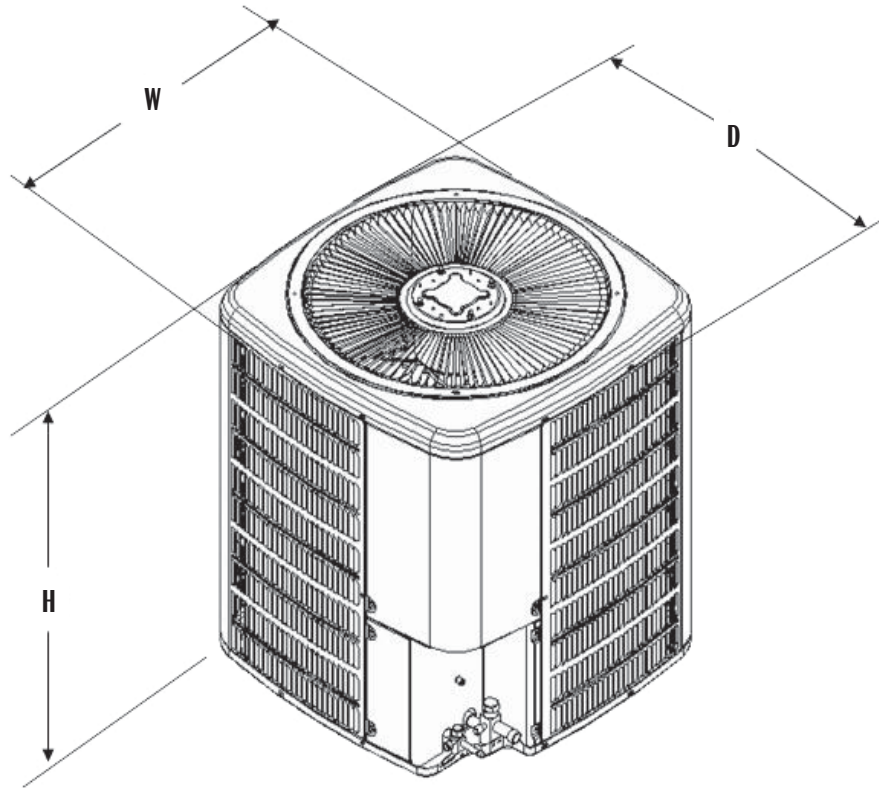

Model	Dimensions W x D x H
SSX140181A	26" x 26" x 32 $\frac{1}{4}$ "
SSX140241A	26" x 26" x 32 $\frac{1}{4}$ "
SSX140301A	29" x 29" x 32 $\frac{1}{4}$ "
SSX140361A	29" x 29" x 34 $\frac{1}{4}$ "
SSX140421A	35 $\frac{1}{2}$ " x 35 $\frac{1}{2}$ " x 38 $\frac{1}{4}$ "
SSX140421B	29" x 29" x 38 $\frac{1}{4}$ "
SSX140481A	35 $\frac{1}{2}$ " x 35 $\frac{1}{2}$ " x 38 $\frac{1}{4}$ "
SSX140601A	35 $\frac{1}{2}$ " x 35 $\frac{1}{2}$ " x 38 $\frac{1}{4}$ "

PERFORMANCE RATINGS

Outdoor Unit	Indoor Units		Cooling Capacity (BTU/h)				ARI #
	Coil & Blower Units	Furnace	Total	Sensible	SEER ¹	EER ²	
SSX14 0181A*	AEPF183016A*+TXV		18,000	12,800	15.00	13.00	1044507
	AEPF183016B*+TXV		18,000	12,800	15.00	13.00	1277829
	ARPF19311A*+TXV		18,000	12,800	14.00	12.00	1038355
	ARUF193116A*+TXV		18,000	12,800	14.00	12.00	1180773
	ASPF183016A*+TXV		18,000	12,800	15.00	12.50	1282746
	CA*F036*4*+BDK+TXV		18,000	12,800	14.00	12.00	922379
	CA*F036*4*+MBE1200**-1+TXV		18,000	12,800	15.00	12.50	921892
	CA*F036*4*+TXV	G*V950453B**	18,400	13,100	15.00	12.50	923395
	CA*F036*4*+TXV	G*V950704C**	18,400	13,100	15.00	12.50	922267
	CA*F036*4*+TXV	G*V80704B**	18,400	13,100	15.00	12.50	924513
	CA*F3131*6A*+EEP+TXV		18,000	12,800	14.00	12.00	921820
	CA*F3131*6A*+MBE1200**-1+TXV		18,400	13,100	15.00	12.50	922796
	CA*F3131*6A*+TXV	G*V950453B**	18,400	13,100	15.00	12.50	924223
	CA*F3131*6A*+TXV	G*V80704B**	18,400	13,100	15.00	12.50	921609
	CA*F3131*6A*+TXV	G*E80704B**	18,400	13,100	15.00	12.50	1259626
	CA*F3131*6A*+TXV	G*V950704C**	18,000	12,800	15.00	12.50	1289416
	CA*F36361*6A*+MBE1200**-1+TXV		18,400	13,100	16.00	13.00	924816
	CHPF036B4*+BDK+TXV		18,000	12,800	14.00	12.00	922692
	CHPF036B4*+MBE1200**-1+TXV		18,000	12,800	15.00	12.00	922152
	CHPF036B4*+TXV	G*V950453B**	18,000	12,800	15.00	12.50	923299
	CHPF036B4*+TXV	G*V80704B**	18,000	12,800	15.00	12.50	923029
	CHPF036C4*+TXV	G*V950704C**	18,000	12,800	15.00	12.50	1008573
	CHPF2430B6A*+EEP+TXV		18,000	12,800	14.00	12.00	922138
	CHPF2430B6A*+MBE1200**-1+TXV		18,000	12,800	15.00	12.00	924183
	CHPF2430B6A*+TXV	G*V950704C**	18,000	12,800	15.00	12.50	922229
	CHPF2430B6A*+TXV	G*V950453B**	18,000	12,800	15.00	12.50	923526
	CHPF2430B6A*+TXV	G*V80704B**	18,000	12,800	15.00	12.50	921202
	CHPF2430B6A*+TXV	G*E80704B**	18,000	12,800	15.00	12.50	1259627
	CSCF3036N6A*+EEP+TXV		18,400	13,100	15.00	12.50	923570
	CSCF3036N6A*+TXV	G*V80704B**	18,400	13,100	15.00	12.50	922153
	CSCF3036N6A*+TXV	G*VE80704B**	18,400	13,100	15.00	12.50	1259628
	CSCF3036N6A*+TXV	G*V950453B**	18,400	13,100	15.00	12.50	924008
	CSCF3036N6A*+TXV	G*V950704C**	18,400	13,100	15.00	12.50	922606
	CSCF3036N6B*+EEP+TXV		18,400	13,100	15.00	12.50	1296808
	CSCF3036N6B*+TXV	G*V80704B**	18,400	13,100	15.00	12.50	1296809
	CSCF3036N6B*+TXV	G*V950453B**	18,400	13,100	15.00	12.50	1296810
CSCF3036N6B*+TXV	G*V950704C**	18,400	13,100	15.00	12.50	1296811	
CSCF3036N6B*+TXV	G*VE80704B**	18,400	13,100	15.00	12.50	1296812	

¹ Seasonal Energy Efficiency Ratio; Certified per ARI 210/240 @ 80°F/ 67°F/ 95°F

² Energy Efficiency Ratio @ 80 °F/67 °F Inside - 95 °F

Notes:

- Always check the S&R plate for electrical data on the unit being installed.
- When matching the outdoor unit to the indoor unit, use the piston supplied with the outdoor unit or what is specified on the piston kit chart supplied with the indoor unit.
- EEP - Order from Service Dept. Part No. B13707-38 or new Solid State Board B13707-35S. Part No. B13707-38 is not interchangeable with B13707-35S. The Goodman Gas Furnace contains the EEP cooling time delay.

PRODUCT SPECIFICATIONS

PERFORMANCE RATINGS (CONT.)

Outdoor Unit	Indoor Units		Cooling Capacity (BTU/h)				ARI #
	Coil & Blower Units	Furnace	Total	Sensible	SEER ¹	EER ²	
SSX14 0241A*	AEPF303616A*		24,000	17,500	15.00	13.00	1126492
	AEPF303616B*		24,000	17,500	15.00	13.00	1277830
	ARPF193116A*		24,000	17,500	14.00	12.00	1038343
	ARUF193116A*		24,000	17,500	14.00	12.00	1038350
	ASPF303616A*		24,000	17,500	15.00	12.50	1282747
	CA*F048*4*	G*V950704C**	23,600	17,200	15.00	12.50	924437
	CA*F048*4*	G*V80704B**	23,600	17,200	15.00	12.50	924297
	CA*F048*4*	G*V80905C**	23,600	17,200	15.00	12.50	921328
	CA*F048*4*	G*V950453B**	23,600	17,200	15.00	12.50	922299
	CA*F048*4**	G*V81155C**	23,600	17,200	15.00	12.50	1008577
	CA*F048*4*+BDK		24,000	17,500	14.00	12.00	924276
	CA*F048*4*+MBE1200**-1		24,000	17,500	15.00	12.50	921496
	CA*F3636*6A*	G*E80704B**	23,600	17,200	15.00	12.50	1259629
	CA*F3636*6A*	G*V950453B**	23,600	17,200	15.00	12.50	921368
	CA*F3636*6A*	G*V80704B**	23,600	17,200	15.00	12.50	924925
	CA*F3636*6A*	G*V950704C**	23,600	17,200	15.00	12.50	924238
	CA*F3636*6A*+EEP		24,000	17,500	14.00	12.00	923529
	CA*F3636*6A*+MBE1200**-1		24,000	17,500	15.00	12.50	923132
	CA*F3642*6A*	G*V950704C**	23,600	17,200	15.00	12.50	923482
	CA*F3642*6A*	G*V81155C**	23,600	17,200	15.00	12.50	1008533
	CHPF048B4*	G*V950704C**	23,600	17,200	15.00	12.50	924794
	CHPF048B4*	G*V950453B**	23,600	17,200	15.00	12.50	923676
	CHPF048B4*	G*V80704B**	23,600	17,200	14.50	12.20	922510
	CHPF3636B6A*	G*V80704B**	23,600	17,200	14.50	12.20	923695
	CHPF3636B6A*	G*E80704B**	23,600	17,200	14.50	12.20	1259630
	CHPF3636B6A*	G*V950453B**	23,600	17,200	15.00	12.50	922673
	CHPF3636B6A*	G*V950704C**	23,600	17,200	15.00	12.50	923693
	CHPF3636B6A*+EEP		24,000	17,500	14.00	12.00	1008538
	CHPF3636B6A*+MBE1200**-1		24,000	17,500	15.00	12.50	1008575
	CHPF3642*6A*	G*V81155C**	23,600	17,200	15.00	12.50	1008574
	CHPF3642C6A*	G*V81155C**	23,000	16,800	15.00	12.50	1008535
	CHPF3642C6A*	G*V80905C**	23,000	16,800	15.00	12.50	921669
	CSCF3036N6A*	G*V80905C**	23,600	17,200	15.00	12.50	922460
	CSCF3036N6A*	G*V950453B**	23,600	17,200	14.50	12.20	922339
	CSCF3036N6A*	G*V80704B**	23,600	17,200	14.50	12.20	921851
	CSCF3036N6A*	G*E80704B**	23,600	17,200	14.50	12.20	1259631
	CSCF3036N6A*	G*V81155C**	23,600	17,200	15.00	12.50	1008537
	CSCF3036N6A*	G*V950704C**	23,600	17,200	14.50	12.20	921792
	CSCF3036N6A*+EEP		23,600	17,200	14.00	12.00	922248
	CSCF3036N6B*	G*E80704B**	23,600	17,200	14.50	12.20	1296813
	CSCF3036N6B*	G*V80704B**	23,600	17,200	14.50	12.20	1296814
	CSCF3036N6B*	G*V80905C**	23,600	17,200	15.00	12.50	1296815
CSCF3036N6B*	G*V81155C**	23,600	17,200	15.00	12.50	1296816	
CSCF3036N6B*	G*V950453B**	23,600	17,200	14.50	12.20	1296817	
CSCF3036N6B*	G*V950704C**	23,600	17,200	14.50	12.20	1296818	
CSCF3036N6B*+EEP		23,600	17,200	14.00	12.00	1296819	

PERFORMANCE RATINGS (CONT.)

Outdoor Unit	Indoor Units		Cooling Capacity (BTU/h)				ARI #
	Coil & Blower Units	Furnace	Total	Sensible	SEER ¹	EER ²	
SSX14 0301A*	AEPF303616A*		28,800	21,000	15.00	13.00	1126493
	AEPF303616B*		28,800	21,000	15.00	13.00	1277831
	AR*F363616A*		28,000	20,400	13.50	11.80	1273405
	ARPF193116A*		28,800	21,000	14.00	12.00	1038351
	ARUF193116A*		28,800	21,000	14.00	12.00	1038344
	ASPF303616A*		29,000	21,200	15.00	12.50	1282748
	CA*F048*4*+MBE1200**-1		28,800	21,000	15.00	12.50	922345
	CA*F057*4*	G*V81155C**	28,800	21,000	15.00	12.50	924518
	CA*F057*4*	G*V950704C**	28,800	21,000	15.00	12.50	922029
	CA*F057*4*	G*V80905C**	28,800	21,000	15.00	12.50	922568
	CA*F3636*6A*+MBE1200**-1		28,800	21,000	15.00	12.50	924419
	CA*F3642*6A*	G*V80905C**	28,800	21,000	15.00	12.50	923699
	CA*F3642*6A*	G*V950704C**	28,800	21,000	15.00	12.50	921461
	CA*F3642*6A*	G*V81155C**	28,800	21,000	15.00	12.50	924469
	CA*F3642*6A*	G*V951155D**	28,600	20,900	14.70	12.30	1289430
	CA*F3642*6A*	G*V950905D**	28,800	21,000	14.70	12.30	1289418
	CA*F3642*6A*+EEP		28,800	21,000	14.00	12.00	922313
	CA*F3642*6A*+TXV	G*E80905C**	28,800	21,000	15.00	12.50	1260520
	CA*F3642*6A*+TXV	G*E81155C**	28,800	21,000	15.00	12.50	1260055
	CHPF048*4*	G*V950704C**	28,800	21,000	15.00	12.50	924987
	CHPF048*4*+EEP		28,800	21,000	14.00	12.00	923101
	CHPF048C4*+MBE1600**-1		28,800	21,000	15.00	12.50	1008576
	CHPF3636B6A*	G*V950453B**	28,800	21,000	15.00	12.50	1008580
	CHPF3636B6A*+MBE1200**-1		28,800	21,000	15.00	12.50	921356
	CHPF3642*6A*	G*V80905C**	28,800	21,000	15.00	12.50	921890
	CHPF3642*6A*	G*V950704C**	28,800	21,000	15.00	12.50	923239
	CHPF3642*6A*+EEP		28,800	21,000	14.00	12.00	921302
	CHPF3642D6A*	G*V81155C**	28,800	21,000	15.00	12.50	1008534
	CHPF3642D6A*+TXV	G*E81155C**	28,800	21,000	15.00	12.50	1260056
	CHPF3642D6A*+TXV	G*E80905C**	28,800	21,000	15.00	12.50	1260521
	CSCF3642N6A*		28,800	21,000	14.00	12.00	1145059
	CSCF3642N6A*	G*V80905C**	28,800	21,000	15.00	12.50	921779
	CSCF3642N6A*	G*V950704C**	28,800	21,000	15.00	12.50	924363
	CSCF3642N6A*	G*V81155C**	28,800	21,000	15.00	12.50	923104
	CSCF3642N6A*+TXV	G*E81155C**	28,800	21,000	15.00	12.50	1260057
	CSCF3642N6A*+TXV	G*E80905C**	28,800	21,000	15.00	12.50	1260522
	CSCF3642N6C*	G*V80905C**	28,800	21,000	15.00	12.50	1296690
	CSCF3642N6C*	G*V81155C**	28,800	21,000	15.00	12.50	1296691
	CSCF3642N6C*	G*V950704C**	28,800	21,000	15.00	12.50	1296692
	CSCF3642N6C*+EEP		28,800	21,000	14.00	12.00	1296852
CSCF3642N6C*+TXV	G*E80905C**	28,800	21,000	15.00	12.50	1296693	
CSCF3642N6C*+TXV	G*E81155C**	28,800	21,000	15.00	12.50	1296694	

¹ Seasonal Energy Efficiency Ratio; Certified per ARI 210/240 @ 80°F/ 67°F/ 95°F

² Energy Efficiency Ratio @ 80 °F/67 °F Inside - 95 °F

See Notes on Page 5.

PRODUCT SPECIFICATIONS

PERFORMANCE RATINGS (CONT.)

Outdoor Unit	Indoor Units		Cooling Capacity (BTU/h)				ARI #
	Coil & Blower Units	Furnace	Total	Sensible	SEER ¹	EER ²	
SSX14 0361A*	AEPF426016A*		34,600	24,600	15.00	13.00	1126494
	AEPF426016B*		34,600	24,600	15.00	13.00	1277832
	AR*F363616A*		35,000	24,900	13.50	11.80	1273406
	ARPF374316A*		35,000	24,900	14.00	12.00	1038349
	ARUF374316A*		35,000	24,900	14.00	12.00	1038352
	ASPF426016A*		34,600	24,600	15.00	12.50	1282749
	CA*F057*4*+EEP		34,600	24,600	14.00	12.00	921210
	CA*F060*4*	G*V950704C**	34,600	24,600	14.50	12.20	922320
	CA*F060*4*	G*V81155C**	34,600	24,600	14.50	12.20	921321
	CA*F060*4*	G*V950905D**	34,600	24,600	14.50	12.20	924414
	CA*F060*4*	G*V80905C**	34,600	24,600	14.50	12.20	924463
	CA*F060*4*	G*V951155D**	34,600	24,600	14.50	12.20	922934
	CA*F060*4*+MBE1600**-1		35,000	24,900	14.50	12.20	923806
	CA*F3642*6A*+EEP		34,600	24,600	14.00	12.00	924566
	CA*F4860*6A*	G*V951155D**	34,600	24,600	14.50	12.20	922705
	CA*F4860*6A*	G*V81155C**	34,600	24,600	14.50	12.20	924464
	CA*F4860*6A*	G*E81155C**	34,600	24,600	15.00	12.50	1273379
	CA*F4860*6A*	G*V950704C**	34,600	24,600	14.50	12.20	924418
	CA*F4860*6A*	G*V80905C**	34,600	24,600	14.50	12.20	924111
	CA*F4860*6A*	G*V950905D**	34,600	24,600	15.00	12.50	924388
	CA*F4860*6A*+MBE1600**-1		35,000	24,900	14.50	12.20	922563
	CHPF048D4*	G*V951155D**	34,600	24,600	15.00	12.20	922840
	CHPF048D4*	G*V81155C**	34,600	24,600	14.50	12.20	924169
	CHPF048D4*	G*V950905D**	34,600	24,600	15.00	12.20	1008536
	CHPF048D4*+EEP		35,000	24,900	14.00	12.00	922188
	CHPF048D4*+MBE2000**-1		35,000	24,900	15.00	12.50	923380
	CHPF3642*6A*	G*V81155C**	34,600	24,600	14.50	12.20	924077
	CHPF3642*6A*	G*E81155C**	34,600	24,600	15.00	12.50	1273380
	CHPF3642*6A*	G*V950704C**	34,600	24,600	14.50	12.20	923842
	CHPF3642*6A*	G*V80905C**	34,600	24,600	14.50	12.20	921909
	CHPF3642D6A*	G*V951155D**	34,600	24,600	15.00	12.20	1008540
	CHPF3642D6A*+EEP		35,000	24,900	14.00	12.00	922035
	CHPF3642D6A*+MBE2000**-1		35,000	24,900	15.00	12.50	924091
	CSCF3642N6A*+EEP		35,000	24,900	14.00	12.00	922408
	CSCF4860N6A*	G*V81155C**	34,600	24,600	14.50	12.20	921400
	CSCF4860N6A*	G*V950704C**	34,600	24,600	14.50	12.20	921446
	CSCF4860N6A*	G*E81155C**	34,600	24,600	15.00	12.50	1273381
	CSCF4860N6A*	G*V950905D**	34,600	24,600	14.50	12.20	923294
	CSCF4860N6A*	G*V951155D**	34,600	24,600	14.50	12.20	922773
	CSCF4860N6A*	G*V80905C**	34,600	24,600	14.50	12.20	1008532
	CSCF3642N6C*+EEP		35,000	24,900	14.00	12.00	1296695
	CSCF4860N6C*	G*E81155C**	34,600	24,600	15.00	12.50	1296820
	CSCF4860N6C*	G*V80905C**	34,600	24,600	14.50	12.20	1296821
CSCF4860N6C*	G*V81155C**	34,600	24,600	14.50	12.20	1296822	
CSCF4860N6C*	G*V950704C**	34,600	24,600	14.50	12.20	1296823	
CSCF4860N6C*	G*V950905D**	34,600	24,600	14.50	12.20	1296824	
CSCF4860N6C*	G*V951155D**	34,600	24,600	14.50	12.20	1296825	

PERFORMANCE RATINGS (CONT.)

Outdoor Unit	Indoor Units		Cooling Capacity (BTU/h)				ARI #
	Coil & Blower Units	Furnace	Total	Sensible	SEER ¹	EER ²	
SSX14 0421A*	AEPF426016A*		40,000	28,400	15.00	13.00	1126495
	AEPF426016B*		40,000	28,400	15.00	13.00	1277833
	ARPF374316A*		39,500	28,000	14.00	12.00	1038337
	ARUF374316A*		39,500	28,000	14.00	12.00	1038342
	ASPF426016A*		40,000	28,400	15.00	12.50	1282745
	CA*F057*4*+MBE2000**-1		40,000	28,400	15.00	12.50	1008581
	CA*F060*4*	G*V950704C**	39,500	28,000	14.00	12.00	924119
	CA*F060*4*	G*V951155D**	40,000	28,400	15.00	12.50	923107
	CA*F060*4*	G*V80905C**	39,500	28,000	14.00	12.00	922509
	CA*F060*4*	G*V950905D**	40,000	28,400	15.00	12.50	924048
	CA*F060*4*	G*V81155C**	39,500	28,000	14.00	12.00	925036
	CA*F060*4*+EEP		40,000	28,400	14.00	12.00	923948
	CA*F060*4*+MBE2000**-1		40,000	28,400	15.00	12.50	924250
	CA*F3642*6A*+MBE2000**-1		40,000	28,400	14.00	12.00	924246
	CA*F4860*6A*	G*V950905D**	40,000	28,400	15.00	12.50	921507
	CA*F4860*6A*	G*V951155D**	40,000	28,400	15.00	12.50	923953
	CA*F4860*6A*	G*V81155C**	39,500	28,000	14.00	12.00	924937
	CA*F4860*6A*	G*V80905C**	39,500	28,000	14.00	12.00	921247
	CA*F4860*6A*	G*V950704C**	39,500	28,000	14.00	12.00	923066
	CA*F4860*6A*+EEP		40,000	28,400	14.00	12.00	921531
	CA*F4860*6A*+MBE2000**-1		40,000	28,400	15.00	12.50	924734
	CA*F4860*6A*+TXV	G*E81155C**	39,500	28,000	15.00	12.50	1273389
	CHPF048D4*+EEP		40,000	28,400	14.00	12.00	923086
	CHPF048D4*+MBE2000**-1		40,000	28,400	15.00	12.50	923989
	CHPF060D4*	G*V951155D**	40,000	28,400	15.00	12.50	923826
	CHPF060D4*	G*V91155D**	40,000	28,400	15.00	12.50	924773
	CHPF060D4*	G*V81155C**	39,500	28,000	14.50	12.00	924458
	CHPF3642D6A*+EEP		40,000	28,400	14.00	12.00	922642
	CHPF4860*6A*	G*V81155C**	39,500	28,000	14.50	12.00	922025
	CHPF4860*6A*+TXV	G*E81155C**	39,500	28,000	15.00	12.50	1273390
	CHPF4860D6A*	G*V951155D**	40,000	28,400	15.00	12.50	1008539
	CHPF4860D6A*+MBE2000**-1		40,000	28,400	15.00	12.50	924016
	CSCF3642N6A*+ EEP		40,000	28,400	14.00	12.00	924742
	CSCF4860N6A*	G*V951155D**	40,000	28,400	15.00	12.50	922170
	CSCF4860N6A*	G*V950905D**	40,000	28,400	15.00	12.50	922282
	CSCF4860N6A*	G*V950704C**	39,500	28,000	14.00	12.00	923296
	CSCF4860N6A*	G*V80905C**	39,500	28,000	14.00	12.00	923786
	CSCF4860N6A*	G*V81155C**	39,500	28,000	14.00	12.00	924038
	CSCF4860N6A*+TXV	G*E81155C**	39,500	28,000	15.00	12.50	1273391
	CSCF3642N6C*+EEP		40,000	28,400	14.00	12.00	1296853
	CSCF4860N6C*	G*V80905C**	39,500	28,000	14.00	12.00	1296826
	CSCF4860N6C*	G*V81155C**	39,500	28,000	14.00	12.00	1296827
CSCF4860N6C*	G*V950704C**	39,500	28,000	14.00	12.00	1296828	
CSCF4860N6C*	G*V950905D**	40,000	28,400	15.00	12.50	1296829	
CSCF4860N6C*	G*V951155D**	40,000	28,400	15.00	12.50	1296830	
CSCF4860N6C*+TXV	G*E81155C**	39,500	28,000	15.00	12.50	1296831	

See Notes on Page 11.

PRODUCT SPECIFICATIONS

PERFORMANCE RATINGS (CONT.)

Outdoor Unit	Indoor Units		Cooling Capacity (BTU/h)				ARI #
	Coil & Blower Units	Furnace	Total	Sensible	SEER ¹	EER ²	
SSX14 0421B*	AEPF426016A*		40,000	28,400	15.00	12.50	1268300
	AEPF426016B*		40,000	28,400	15.00	12.50	1277834
	ARPF374316A*		39,500	28,000	14.00	12.00	1268299
	ARUF374316A*		39,500	28,000	14.00	12.00	1268298
	ASPF426016A*		40,000	28,400	15.00	12.50	1268301
	CA*F4860*6A*	G*V81155C**	39,500	28,000	14.00	12.00	1268307
	CA*F4860*6A*	G*V90905D**	40,000	28,400	15.00	12.50	1268302
	CA*F4860*6A*	G*V950704C**	39,500	28,000	14.00	12.00	1268296
	CA*F4860*6A*	G*V80905C**	39,500	28,000	14.00	12.00	1268293
	CA*F4860*6A*	A/G*V951155D**	40,000	28,400	15.00	12.50	1268289
	CA*F4860*6A*	G*V950905D**	40,000	28,400	15.00	12.50	1268304
	CA*F4860*6A*+EEP		40,000	28,400	14.00	12.00	1275166
	CA*F4860*6A*+MBE2000**-1		40,000	28,400	15.00	12.50	1270694
	CA*F4860*6A*+MBE2000**-1		40,000	28,400	15.00	12.50	1268295
	CHPF4860D6A*	G*V81155C**	39,500	28,000	14.00	12.00	1268292
	CHPF4860D6A*	G*V950905D**	40,000	28,400	15.00	12.50	1268305
	CHPF4860D6A*	G*V80905C**	39,500	28,000	14.00	12.00	1268294
	CHPF4860D6A*MBE2000**-1		40,000	28,400	15.00	12.50	1261868
	CHPF4860D6A*	A/G*V951155D**	40,000	28,400	15.00	12.50	1268290
	CHPF4860D6A*	G*V90905D**	40,000	28,400	15.00	12.50	1268291
	CHPF4860D6A*	G*V950704C**	40,000	28,400	14.00	12.00	1268297
	CHPF4860D6A*+EEP		40,000	28,400	14.00	12.00	1270697
	CHPF4860D6A*+MBE2000**-1		40,000	28,400	15.00	12.50	1270695
	CSCF4860N6A*	G*V950905D**	40,000	28,400	15.00	12.50	1268306
	CSCF4860N6A*	G*V950704C**	40,000	28,400	14.00	12.00	1268310
	CSCF4860N6A*	A/G*V951155D**	40,000	28,400	15.00	12.50	1268303
	CSCF4860N6A*	G*V81155C**	39,500	28,000	14.00	12.00	1268308
	CSCF4860N6A*	G*V80905C**	39,500	28,000	14.00	12.00	1268309
	CSCF4860N6A*+EEP		40,000	28,400	14.00	12.00	1270698
	CSCF4860N6A*+MBE2000**-1		40,000	28,400	15.00	12.50	1268340
	CSCF4860N6A*+MBE2000**-1		40,000	28,400	15.00	12.50	1268339
	CSCF4860N6C*	A/G*V951155D**	40,000	28,400	15.00	12.50	1296832
	CSCF4860N6C*	G*V80905C**	39,500	28,000	14.00	12.00	1296833
	CSCF4860N6C*	G*V81155C**	39,500	28,000	14.00	12.00	1296834
	CSCF4860N6C*	G*V950704C**	40,000	28,400	14.00	12.00	1296835
	CSCF4860N6C*	G*V950905D**	40,000	28,400	15.00	12.50	1296836
	CSCF4860N6C*+EEP		40,000	28,400	14.00	12.00	1296837
	CSCF4860N6C*+MBE2000**-1		40,000	28,400	15.00	12.50	1296696
	CSCF4860N6C*+MBE2000**-1		40,000	28,400	15.00	12.50	1296697

PERFORMANCE RATINGS (CONT.)

Outdoor Unit	Indoor Units		Cooling Capacity (BTU/h)				ARI #
	Coil & Blower Units	Furnace	Total	Sensible	SEER ¹	EER ²	
SSX14 0481A*	AEPF426016A*		46,000	33,600	14.50	11.80	1180827
	AEPF426016B*		46,000	33,600	14.50	11.80	1277835
	ARPF374316A*		46,000	33,600	14.00	12.00	1038339
	ARUF374316A*		46,000	33,600	14.00	12.00	1038338
	ASPF426016A*		47,000	34,300	15.00	12.50	1282744
	CA*F060*4*	G*V951155D**	45,500	33,200	15.00	12.50	922372
	CA*F060*4*	G*V950905D**	45,500	33,200	15.00	12.50	924510
	CA*F060*4*	G*V90905D**	45,500	33,200	15.00	12.50	923080
	CA*F060*4*+EEP		46,000	33,600	14.00	12.00	925039
	CA*F060*4*+MBE2000**-1		46,000	33,600	15.50	13.00	923810
	CA*F4860*6A*	G*V951155D**	45,500	33,200	15.00	12.50	924446
	CA*F4860*6A*	G*V80905C**	45,500	33,200	15.00	12.50	1008561
	CA*F4860*6A*	G*V950905D**	45,500	33,200	15.00	12.50	921492
	CA*F4860*6A*+EEP		46,000	33,600	14.00	12.00	923927
	CA*F4860*6A*+MBE2000**-1		46,000	33,600	15.50	13.00	923133
	CA*F4860*6A*+TXV	G*E80905C**	45,500	33,200	14.50	12.00	1273392
	CHPF060D4*	G*V951155D**	45,500	33,200	15.00	12.50	923549
	CHPF060D4*	G*V950905D**	45,500	33,200	15.00	12.50	921940
	CHPF060D4*	G*V90905D**	45,500	33,200	15.00	12.50	923320
	CHPF060D4*+BDK		46,000	33,600	14.00	12.00	921568
	CHPF060D4*+MBE2000**-1		46,000	33,600	15.50	13.00	922717
	CHPF4860D6A*	G*V950905D**	45,500	33,200	15.00	12.50	924141
	CHPF4860D6A*	G*V90905D**	45,500	33,200	15.00	12.50	922846
	CHPF4860D6A*	G*V951155D**	45,500	33,200	15.00	12.50	924085
	CHPF4860D6A*+EEP		46,000	33,600	14.00	12.00	924342
	CHPF4860D6A*+MBE2000**-1		46,000	33,600	15.50	13.00	922597
	CSCF4860N6A*	G*V950905D**	45,500	33,200	14.50	12.25	922930
	CSCF4860N6A*	G*V951155D**	45,500	33,200	14.50	12.25	923013
	CSCF4860N6A*+EEP		46,000	33,600	14.00	12.00	924130
	CSCF4860N6C*	G*V950905D**	45,500	33,200	14.50	12.25	1296838
CSCF4860N6C*	G*V951155D**	45,500	33,200	14.50	12.25	1296839	
CSCF4860N6C*+EEP		46,000	33,600	14.00	12.00	1296840	

¹ Seasonal Energy Efficiency Ratio
² Energy Efficiency Ratio @ 80 °F/67 °F Inside - 95 °F

Notes:

- Always check the S&R plate for electrical data on the unit being installed.
- When matching the outdoor unit to the indoor unit, use the piston supplied with the outdoor unit or what is specified on the piston kit chart supplied with the indoor unit.
- EEP - Order from Service Dept. Part No. B13707-38 or new Solid State Board B13707-35S. Part No. B13707-38 is not interchangeable with B13707-35S. The Goodman Gas Furnace contains the EEP cooling time delay.

PRODUCT SPECIFICATIONS

PERFORMANCE RATINGS (CONT.)

Outdoor Unit	Indoor Units		Cooling Capacity (BTU/h)				ARI #
	Coil & Blower Units	Furnace	Total	Sensible	SEER ¹	EER ²	
SSX14 0601A*	AEPF426016A*		56,000	39,800	14.30	11.70	1180828
	AEPF426016B*		56,000	39,800	14.30	11.70	1277836
	ARPF374316A*		57,000	40,500	13.50	11.50	1038341
	ARPF486016A*		56,000	39,800	13.50	11.50	1180830
	ARUF374316A*		57,000	40,500	13.50	11.50	1038340
	ARUF486016A*		56,000	39,800	13.50	11.50	1180829
	ASPF426016A*		57,000	40,500	14.50	12.00	1282741
	CA*F060*4*	G*V90905D**	56,000	39,800	13.50	11.50	922853
	CA*F060*4*	G*V951155D**	56,000	39,800	13.50	11.50	921662
	CA*F060*4*+EEP		56,000	39,800	14.00	12.00	924951
	CA*F060*4*+MBE2000**-1		56,000	39,800	15.00	12.50	922691
	CA*F060*4*+MBR2000**-1		56,000	39,800	14.00	12.00	922169
	CA*F4860*6A*	G*V951155D**	56,000	39,800	13.50	11.50	923608
	CA*F4860*6A*	G*V90905D**	56,000	39,800	13.50	11.50	924968
	CA*F4860*6A*+EEP		56,000	39,800	14.00	12.00	923143
	CA*F4860*6A*+MBE2000**-1		56,000	39,800	15.00	12.50	921315
	CA*F4860*6A*+MBR2000**-1		56,000	39,800	14.00	12.00	922325
	CHPF060D4*	G*V951155D**	56,000	39,800	13.50	11.50	924069
	CHPF060D4*	G*V950905D**	56,000	39,800	13.50	11.50	922982
	CHPF060D4*+EEP		56,000	39,800	14.00	12.00	922719
	CHPF060D4*+MBR2000**-1		56,000	39,800	14.00	12.00	924188
	CHPF4860D6A*	G*V951155D**	56,000	39,800	13.50	11.50	922176
	CHPF4860D6A*	G*V950905D**	56,000	39,800	13.50	11.50	921819
	CHPF4860D6A*+EEP		56,000	39,800	14.00	12.00	924675
	CHPF4860D6A*+MBR2000**-1		56,000	39,800	14.00	12.00	923184
	CSCF4860N6A*	G*V951155D**	56,000	39,800	13.50	11.50	923409
	CSCF4860N6A*	G*V950905D**	56,000	39,800	13.50	11.50	924157
	CSCF4860N6A*+EEP		56,000	39,800	14.00	12.00	921701
	CSCF4860N6A*+MBE2000**-1		56,000	39,800	15.00	12.00	921346
	CSCF4860N6A*+MBR2000**-1		56,000	39,800	14.00	12.00	923750
	CSCF4860N6C*	G*V950905D**	56,000	39,800	13.50	11.50	1296841
	CSCF4860N6C*	G*V951155D**	56,000	39,800	13.50	11.50	1296842
	CSCF4860N6C*+EEP		56,000	39,800	14.00	12.00	1296843
CSCF4860N6C*+MBE2000**-1		56,000	39,800	15.00	12.00	1296698	
CSCF4860N6C*+MBR2000**-1		56,000	39,800	14.00	12.00	1296699	

¹ Seasonal Energy Efficiency Ratio; Certified per ARI 210/240 @ 80°F/ 67°F/ 95°F

² Energy Efficiency Ratio @ 80 °F/67 °F Inside - 95 °F

See Notes on previous page.



Air Conditioning & Heating

Goodman Manufacturing Company, L.P., reserves the right to discontinue, or change at any time, specifications or designs without notice or without incurring obligations.

Copyright © 2007 • Goodman Manufacturing Company, L.P. • Houston, Texas
Printed in the USA.